



Installation Instructions Extended Cable/Line Kit 2011-2013 FLST/FXST

WARNINGS & ALERTS

- This kit is designed for controlling Harley-Davidson OEM components only.
- After installing this kit, models equipped with ABS must have the brake system serviced/checked at an authorized Harley Davidson service center prior to riding the motorcycle. Failure to do so could lead to a brake system malfunction resulting in loss of control, injury, or death.
- The operator must use extreme caution when operating a modified motorcycle, particularly while familiarizing himself with its altered characteristics.
- Once installation is complete, be certain ALL controls are properly adjusted to the specifications outlined in your factory authorized service manual before attempting to operate your motorcycle.

LIMITED GUARANTEE

We continually inspect and try to improve our products. All parts have been inspected prior to packaging, and our guarantee is limited to replacement of defective parts. This guarantee is in lieu of all guarantees or warranties implied or expressed. Because we cannot control the application of our products, buyer assumes risks for any and all damage caused by himself or third party, by virtue of failure of these parts. We make no warranty as to products distributed by us, expressed or implied, including without limitation any warranties or merchant ability and fitness for a particular purpose. We will however, pass on all warranties made by the manufacturer, who has sole responsibility for performing such warranties. The manufacturer shall solely be responsible for any damage to person or property arising from design, manufacturing and testing of all products, and we accept no liability for such damages. We shall not be liable for indirect or consequential damages.

PARTS INCLUDED



**BLACK FINISH SHOWN
BRAIDED STAINLESS KITS
ALSO AVAILABLE**

Read all the instructions carefully and be sure you have the proper tools and skills needed before installing this kit on your motorcycle. Use your authorized Harley-Davidson service manual as a reference while installing this kit.

DISASSEMBLY INSTRUCTIONS

In preparation to install your new handlebars and control extension kit, the following must first be removed per your authorized factory service manual:

- Disconnect Battery.
- Remove your stock control cables - Throttle, Idle, and Clutch cables - noting routing.
- Drain your front brake reservoir & brake line and remove your stock brake line.
- Locate and gain access to where the main wiring harness connects to the handlebar controls (and handlebar mounted turn signals if so equipped). This is typically just under the fuel tank on the right behind the steering head (loosen tank and lift slightly). Remove any wire-ties and unplug the left & right control harnesses noting which plug goes to which side - there should be one for the left and two for the right (one smaller than the other).

NOTE: Some models have handlebar mounted turn signals that are not factory wired through the control harness - rather they have their own separate harness that plugs into the main wiring harness independent of the control harnesses. You will have to unplug this from the main harness as well and extend them separately using the included turn signal extension kit (as outlined later).

- Remove the left handgrip, throttle, both handlebar switch housings along with the wiring coming out of them.

NOTE: If your handlebar wiring is mounted outside of the bars, you need to remove all wire ties that hold the wiring in place. If the wiring is run through the bars, cut the AMP connector housings off the ends of the left and right control wiring harness and carefully pull the control wire harness out of the handlebars. Pull on the harness, not on the control housing itself.

- Remove stock handlebars.

After completing these tasks, proceed with the three installation procedures (wiring, control cables, & brake-line) starting on page two.



WIRING HARNESS EXTENSION & INSTALLATION INSTRUCTIONS

- As with any repair or modification involving the wiring system, first disconnect the battery.
- Starting with the control harness extension kit (9 wire kit - 4 into 1 plug, 5 into 2 plugs) there should be a large diameter (3/8") heat-shrink tube over each of the two harness - if not slide one of the supplied larger diameter heat-shrink tubes onto each of the harness, and up towards the connectors to give room to solder.
- Then cut the supplied smaller diameter (1/8") heat-shrink tubing into 9 equal pieces and prepare each harness extension for soldering by first sliding one of the small diameter heat-shrink tube pieces over each of the wire ends and sliding them out of your way for now.
- Strip and prepare the ends of each wire coming out of the left and right control harnesses – note there will be four on the left and four plus one more on the right, a white wire with a thin black stripe (that is NOT twisted together with the white/red wire). While preparing the wires for soldering try to stagger the lengths slightly, this makes it easier to slide the large heat-shrink tubing back over the soldered connections and ultimately easier to install into the handlebars.
- Match up the wire colors on each side with the extension wires in the kit and solder them to their mates (figure 1). Be sure to match the twisted pair of wires (white-black/white-red) to the twisted pair in the extension harness.
- Once you've soldered all the wires, essentially lengthening the left and right control harnesses, one at a time slide the heat-shrink tubing down over the solder point and use a heat gun to apply heat until the tubing has shrunk snugly around both wires and their soldered joint. Repeat for all the extended wires. Then slide the larger diameter heat-shrink tubing over the all the now covered connections and using a heat gun shrink that tubing snugly over them (figure 2).

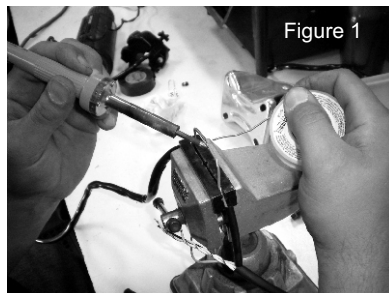

Figure 1

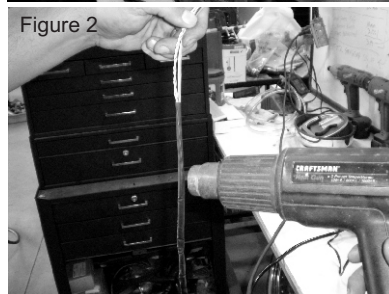

Figure 2

Extending the turn signal wires individually (not necessary on all models)

- If your turn signals are factory wired directly into your left & right control housing or they are not mounted on your handlebars at all – there is no need to extend your turn signal wiring and you can skip to the next step ("fishing" the wires through the handlebars). However if your model has the turn signals mounted on the handlebars AND they have their own wiring harnesses going down to the frame then you'll need to use the supplied 6 wire turn signal extension kit to extend these harnesses. You will be extending the wires coming from the turn signals individually, and to do so you will have to remove the wires – 3 left and 3 right – from the AMP connector. This connector is generally located just behind the steering-head and on the right, under the front of the fuel tank (see figure 3). Before removing any wires note down which color wires are in which sockets in the connector. Use the diagram below this paragraph to help by writing down which color wire is where in the connector. To remove the wires (reference figure 4) first release the connector's (a) secondary lock (b) towards the rear of the connector (where the wires come out) by bending back the latch (c) on each side of the connector, and hinge the secondary lock (b) outward. Look in the terminal side of the connector (opposite the secondary lock) and note the cavity next to each terminal. Insert a small pick, straight pin, or straightened paper-clip into the cavity until it stops. Press the internal primary locking tang (d) away from the terminal socket, thus releasing it from the housing, and gently tug the wire and terminal socket (e) free of the connector housing (a). Now with all the wires free of the connector housing, choose the corresponding color extension wire from the Burly kit and firmly plug the proper end onto the wire on the turn signal harness. If there is no corresponding color extension wire, then choose the closest color and be sure to note the new color next to the old one on the diagram you wrote the original color and positions on below. Repeat for all wires. The most important thing is that the same wire (though now extended) gets back into the same position in the connector housing – but do not reinstall the wires into the housing yet. One by one, slide the smaller 1/8" inch heat-shrink tubing over each extension connection and apply heat from a heat gun until the tubing has shrunk snugly around the connection. After doing this to all the wires, slide the large 3/8" inch heat-shrink tubing over each set of wires (3 left, 3 right) and apply heat from a heat gun until they are snugly wrapped into a tight bundle. At this point, if you are running your wires through your handlebars, you should do this now before reinstalling them into the connector housing. Using the notes you made earlier regarding which color wire goes in which position in the connector housing – noting any color variations of the extensions – push the proper color wire contact straight into the connector housing until a "click" is felt. A slight tug will confirm that it is locked into place. Repeat for all 6 wires (3 left, 3 right). Once all the contacts are back in place, re-lock the secondary lock at the rear of the connector housing.



Figure 3

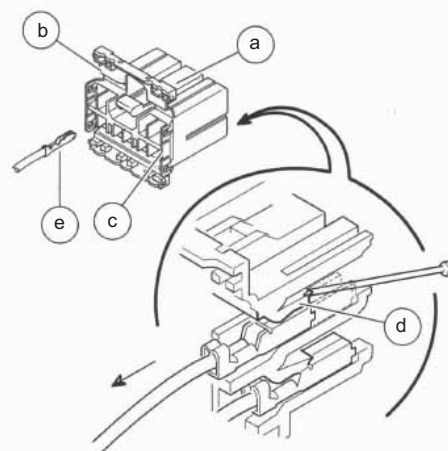
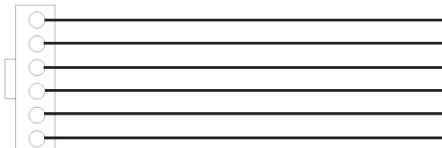

Figure 4

- (a) - Connector Housing
- (b) - Secondary Lock
- (c) - Latch
- (d) - Primary Locking Tang
- (e) - Terminal Socket & Wire

Wiring Chart

write the wire's color on the line corresponding with the position it came out of the connector.





WIRING HARNESS EXTENSION & INSTALLATION INSTRUCTIONS (Cont.)

- Using a wire "fish tape" tool or similar (thin wire coat-hanger, or safety wire) fish all the wires through your new handlebars from the bar-ends down to the middle and out to where the main harness connectors will be located. It is best to fish the wire tool up through the bars in the middle (figure 5) and out by the control area first, then secure the newly extended wire harness to that wire tool (figure 6) and carefully "pull" the wire harness back down through the handlebars to the center and out, while feeding the harness into the bar at the control area (figure 7). Repeat on other side (figures 8).
- Install new handlebars and reinstall left and right handlebar control switches & turn signals (if removed) per your factory authorized service manual.
- At this point you are ready to plug your left and right handlebar control harnesses backing into the main harness – be sure to plug the left plug into the left socket and the right plugs (both of them) into the right sockets. Also don't forget to plug the turn signal harness back in too (if separate from the control harnesses). Now hook the battery back up and make sure everything functions properly. After doing that, re-secure the wire harness at the same points it was secured and reinstall the fuel tank per your factory authorized service manual and proceed to cable and brake line installation.

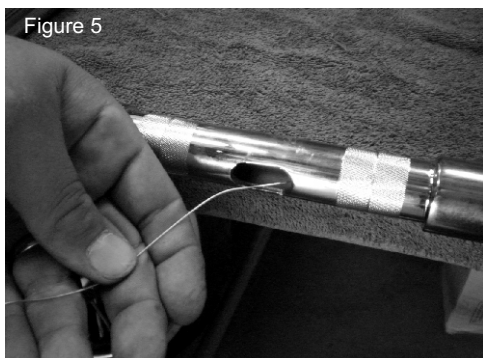

CONTROL CABLE INSTALLATION INSTRUCTIONS

- Install the Burly extended control cables as you would stock cables per your factory authorized service manual - noting to route the new longer cables in such a manner that no kinking or binding occurs through entire range of steering. Check this by turning the handlebars all the way to the left and right while operating the controls.
- Adjust the Clutch, Throttle, & Idle cables per the procedure described in your factory authorized service manual to ensure proper operation.

BRAKE LINE INSTALLATION INSTRUCTIONS

- Install the Burly extended Brake Line as you would stock brake line per your factory authorized service manual - noting to route the new longer Brake Line in such a manner that no kinking or binding occurs through entire range of steering. Check this by turning the handlebars all the way to the left and right while carefully observing the Brake Line. Also make sure there is no binding or stretching of the when fork is completely extended or compressed.
- Refill the brake system with the recommended fluid and bleed any air out of it per the procedure described in your factory authorized service manual.

WARNING - Models equipped with ABS must have the brake system serviced by an authorized Harley Davidson service center prior to riding the motorcycle. Failure to do so could lead to a brake system malfunction resulting in loss of control, injury, or death.

After installing these components it is vital that ALL controls must be adjusted to the recommend specifications noted in your factory authorized service manual. DO NOT attempt to operate the vehicle before making such adjustments or damage, injury, or death may result.